

SERVICE MANUAL

STEREO CASSETTE DECK

SANSUI D-150M

(Silver & Black Model)

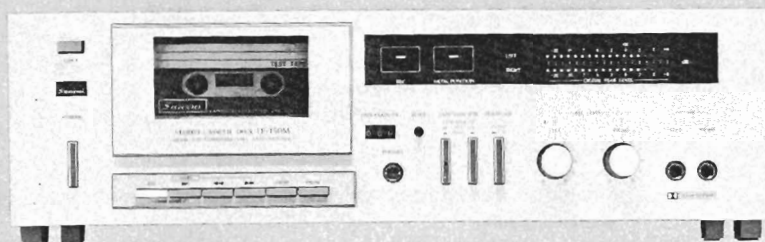

• SPECIFICATIONS

Track	4-Track (2-Channel Stereo)
Tape speed	4.8 cm/sec. (1-7/8 ips)
Motor	Electronically Controlled DC Motor
Wow and flutter	within 0.05 % WRMS
Fast wind time	approximately 95 seconds (C-60)
Frequency response (Record/Playback)	
Normal Tape (LH) (-20 VU)	20 to 15,000 Hz
(0 VU)	(30 to 14,000 Hz \pm 3 dB)
Metal Tape (-20 VU)	20 to 17,000 Hz
(0 VU)	(30 to 15,000 Hz \pm 3 dB)
(0 VU)	30 to 13,000 Hz \pm 3 dB
Signal to noise ratio (Record/Playback)	
Metal Tape (without Dolby Noise Reduction Effect)	better than 58 dB (weighted)
(With Dolby Noise Reduction)	better than 68 dB (above 5 kHz)
Erasur factor (Metal Tape)	more than 65 dB at 1,000 Hz
Input sensitivity and impedance (0 VU, 1,000 Hz)	
MIC	0.4 mV/200 Ω ~ 5 k Ω
LINE IN (REC)	70 mV/47 k Ω
Output level (0 VU, 1,000 Hz)	
LINE OUT (PLAY)	400 mV
PHONES	40 mV
Power requirements	
Power voltage	110 ~ 120, 220 ~ 240 V (50/60 Hz)
For U.S.A. and Canada	120 V (60 Hz)
Power consumption	14 W
Dimensions	430 mm (16-15/16") W
	132 mm (5-1/4") H
	232 mm (9-1/8") D
Weight	4.2 kg (9.3 lbs) net
	4.9 kg (10.8 lbs) packed

* Design and specifications subject to changes without notice for improvements.

Sansui

SANSUI ELECTRIC CO., LTD.

1. OPERATIONS

1-1. Motion of Mechanism Section

A. Mechanism drive unit (See Fig. 1-3, Fig. 1-4 and the mechanism exploded view in page 7,8)

- 1) When a control button is pressed, the button lever causes the select arm and the moving plate to move.
- 2) When the start lever moves, the assist gear is unlocked and starts rotating as meshed with the flywheel gear. Then the cam of the assist gear causes the slide plate to move.
- 3) The select arm of the pressed button pushes up the plate. This plate is locked in the pushed up position by the lock plate (play/rec lock plate 64, FF/REW lock plate 190 or pause lock plate 37).
- 4) The slide plate then returns to the original position, and the assist gear moves away from the flywheel gear and stops.

B. PLAY motion (See Fig. 1-1 and Fig. 1-3)

- 1) When the PLAY button is pressed, the head base is pushed up through the play plate by the drive unit.
- 2) The pinch roller contacts the capstan shaft with pressure in this state, and causes the tape to run at a fixed speed. The play idler ass'y contacts the pulley of the tension ass'y and also the take-up reel hub ass'y with pressure and causes the tape to be wound. (Fig. 1-1 A)

C. REC motion (See Fig. 1-4, Top View in page 10 and mechanism exploded view in page 7,8)

- 1) The tape running motion is same as that in PLAY motion. When a cassette tape with erroneous clearing preventive pawl is mounted, recording preventive lever 7 is pushed up, and the REC button may be pressed.
- 2) When the REC button is pressed, REC/PLAY switch (PS1) in the REC/PLAY amplifier is switched to recording state from playing state by the drive unit through the REC lever and flexible wire.
- 3) The mechanism is such that the PLAY button is also ON when the REC button is pressed.
- 4) A protection device is provided in order not to allow PLAY, FF or REW button to be pressed by mistake during REC motion.

D. FF motion and REW motion (See Fig. 1-1 and Fig. 1-3)

- 1) When the FF button is pressed, the FF plate is pushed up by the drive unit, causing the gear of the tension ass'y to be meshed with the idler gear linked with the take-up reel hub ass'y. As a result, motor revolution is transmitted to tension ass'y, idler gear and take-up reel hub ass'y in this order. (Fig. 1-1 B, Fig. 1-3 B)
- 2) When the REW button is pressed, the REW plate is pushed up by the drive unit, causing the gear of the tension ass'y to be meshed with the gear of the supply reel hub. As a result, motor revolution is transmitted to tension ass'y and supply reel hub in this order. (Fig. 1-1 C, Fig. 1-3 C)

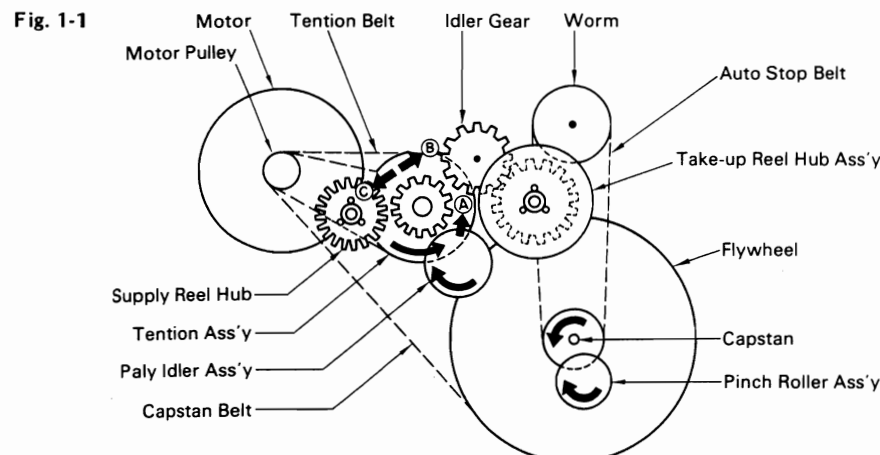

E. PAUSE motion (See Fig. 1-3)

- 1) The PAUSE motion may be made only during PLAY or REC motion.
- 2) When the PAUSE button is pressed, the PAUSE plate is pushed up by the drive unit, causing the pinch roller to move away from the capstan shaft and also causing through the PAUSE arm the play idler to move away from the take-up reel hub ass'y. The tape stops running as a result.
- 3) Simultaneously, the sensor arm and the sensor are pressed to release the auto stop, for maintaining PAUSE motion even when the tape stops.

F. AUTO STOP motion (See Fig. 1-2)

The AUTO STOP mechanism causes all the motions (except for PAUSE motion) to stop when the tape stops running.

- 1) While the tape is running, the revolution of the take-up reel hub ass'y is transmitted to the sensor, and therefore, the sensor is always attempting to rotate in the direction of its rotation. Consequently, even when pawl T of the auto stop cam ass'y approaches the sensor, the sensor moves away from this pawl.
- 2) When the running terminates, rotation of the take-up reel hub ass'y also terminates. Therefore, the sensor loses the force to rotate. As a result, it is pushed by pawl T of the auto stop cam ass'y, and pushes the stop lever and the lock plate, causing each motion to terminate.

G. AMPS motion (See Fig. 1-1, Fig. 1-3 and mechanism exploded view in page 7)

- 1) When the FF (REW) button is pressed during PLAY motion, the FF (REW) plate is pushed up by the drive unit. At the same time, the cue arm pushes the head base down by 1.5 mm.
- 2) The FF (REW) plate causes the gear of the tension ass'y to be meshed with the idler gear (gear of supply reel hub). The FF (REW) plate is locked in this state, allowing FF (REW) motion.
- 3) When a no-signal portion of the cassette tape arrives the head, FF/REW lock plate 190 is pushed by plunger (aPS1). As a result, FF (REW) motion only is released and PLAY motion starts again.

H. TIMER PLAY/REC motion (See Fig. 1-4)

The PLAY and REC button levers are equipped with button lock mechanisms, and when the play (REC) button is pressed, the button lever is locked. Consequently, the PLAY (REC) button is kept in the pressed state. If the timer is set in this state, the power is on when the set time comes, the motor starts running, the drive unit operates and TIMER PLAY (REC) motion is performed.

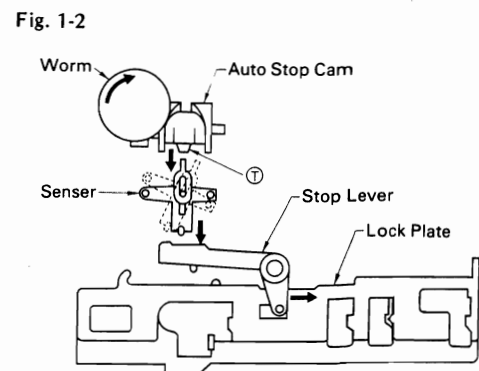

Fig. 1-3

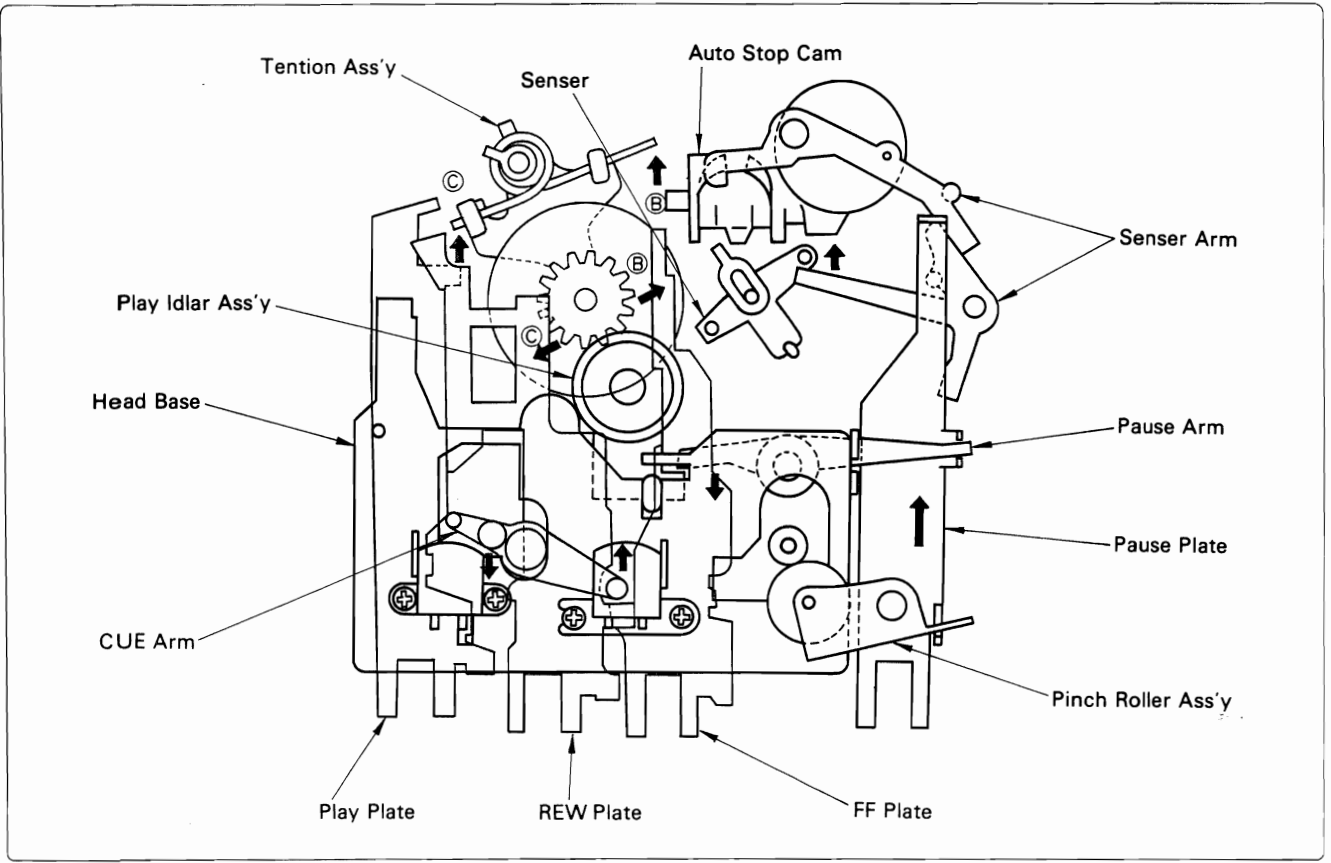
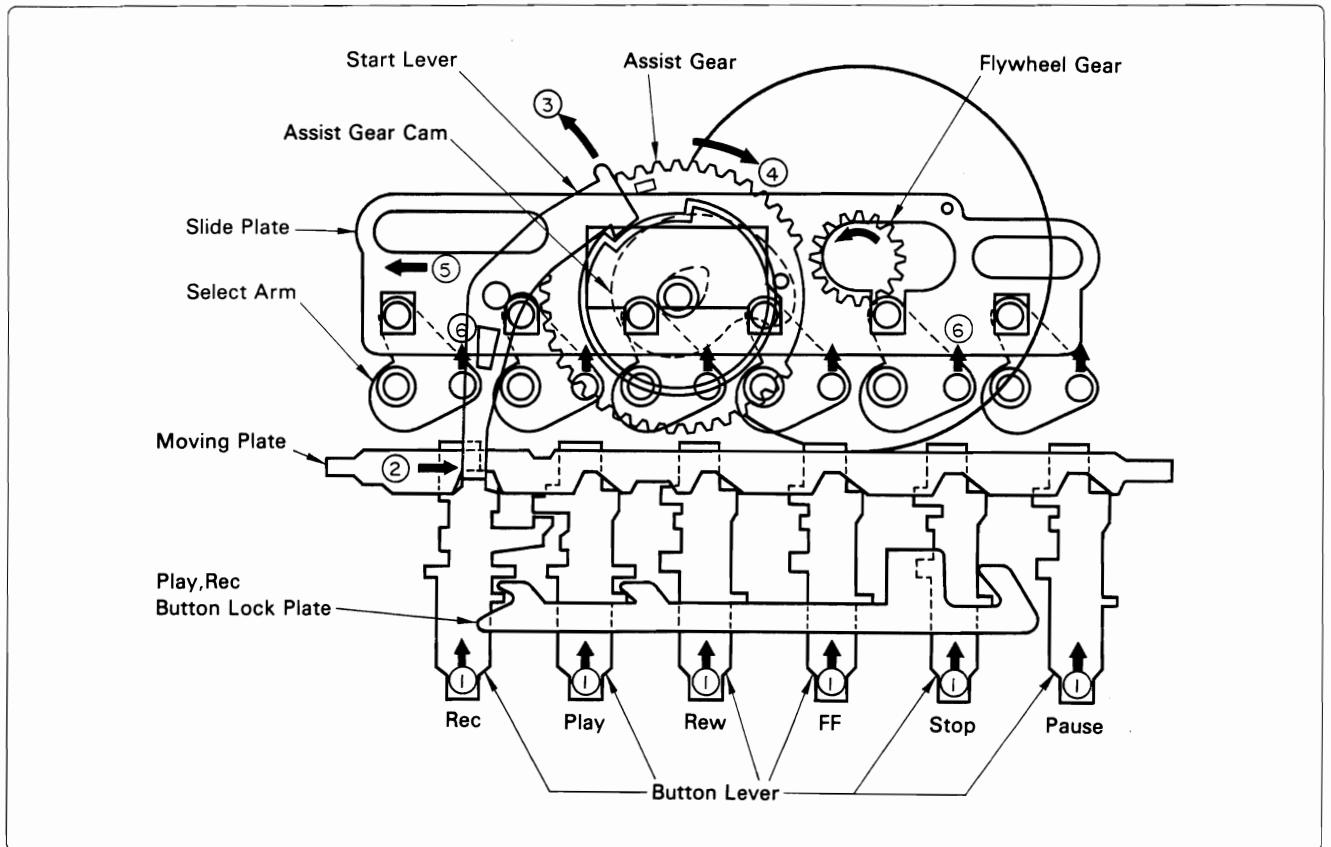

Fig. 1-4



3. ADJUSTMENTS

3-1. Tape Speed Adjustment

Note: 1. Use Sansui Test Tape, SCT-S3K (3 kHz signals are recorded on the tape).
2. Connections are shown in Fig. 3-1.

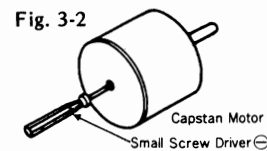
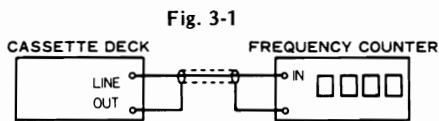

STEP	SUBJECT	MEASURE OUTPUT	SETTING	ADJUSTMENT	ADJUST FOR	REMARKS
1.	TAPE SPEED Adj.	LINE OUT Frequency counter	Playback the TEST TAPE SCT-S3K.	Turn semi-variable resistor as Fig. 3-2.	3000 Hz \pm 45 Hz	Use small screw driver.

3-2. Playback Adjustment

Note: 1. Before this adjustment, clean REC/P.B. head surface.
2. For this adjustment, use Sansui Test Tape, SCT-F10KN, SCT-L400N and SCT-F1K.
3. Set the Dolby NR switch to be OFF.
4. Connections are shown in Fig. 3-3.

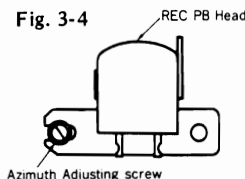
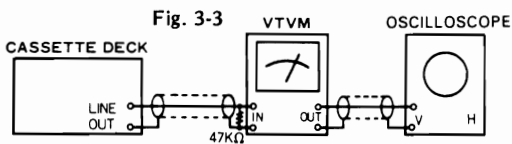

STEP	SUBJECT	MEASURE OUTPUT	SETTING	ADJUSTMENT	ADJUST FOR	REMARKS
1.	REC/P.B. Head Adj.	LINE OUT VTVM, Scope	Playback the TEST TAPE SCT-F10KN	Adjust the azimuth adjusting screw in Fig. 3-4.	MAX. Output on both channels.	After this adjustment, lock the screw with paint.
2.	Playback Level Adj.	Same as above	Set TAPE SELECTOR to NORMAL (LH) position. Playback the TEST TAPE SCT-L400N.	Adjust each fVR1 on L-CH and R-CH.	500 mV \pm 2 dB	See Top View on page 10.
3.	High Frequency Equalization Check	Same as above	Set TAPE SELECTOR to NORMAL (LH) position. Playback the TEST TAPE SCT-F1K.	---	---	Read output levels on both channels.
			Playback the TEST TAPE SCT-F10KN.	---	---	Confirm that the output levels are within \pm 3 dB comparing with the above readings.

Note: On STEP 3, set the TAPE SELECTOR to HIGH (CrO₂) position during playback of SCT-10KN, and confirm the indication on VTVM drops approximately 3 dB ~ 4 dB.

3-3. Recording Adjustment

1) Bias Adjustment

*Adjust this step, when replacing bias osc circuit, variable resistor for bias adjustment or REC/PB head. Adjust in step 2) 2. Frequency Response Adj. on page 5 usually.

Note: 1. For this adjustment, use Sansui Test Tape, SCT-SA.
2. Set the Dolby NR Switch to be OFF.
3. Connections are shown in Fig. 3-5.

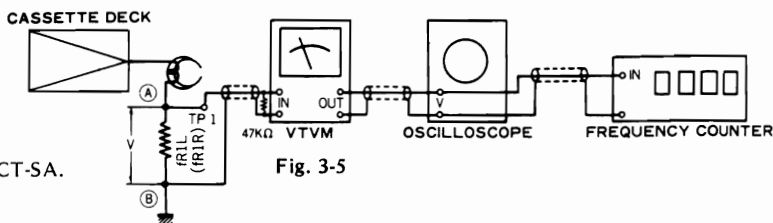

STEP	SUBJECT	MEASURE OUTPUT	SETTING	ADJUSTMENT	ADJUST FOR	REMARKS
1.	Recording Bias Adj.	Between A & B points of each fR1L & fR1R. VTVM, Scope, Frequency Counter	Load the TEST TAPE SCT-SA. Depress PAUSE, REC and PLAY buttons. Set TAPE SELECTOR to HIGH (CrO ₂) position.	Adjust kVR1L for L-CH and kVR1R for R-CH.	8.5mV	See Top View on page 10.
			Set TAPE SELECTOR to NORMAL (LH) position.	---	---	Confirm the indication on VTVM shows 6.5mV.
			Set TAPE SELECTOR to METAL position.	---	---	Confirm the indication on VTVM shows 12mV.
2.	Bias Frequency Check	Same as above	Load the TEST TAPE SCT-SA. Set TAPE SELEC-	---	---	Confirm that the Frequency Counter shows 85 kHz \pm 10 kHz.

2) Rec Level & Frequency Response Adjustment

Note: 1. Rec Level Volume Max.

2. Connections are shown in Fig. 3-6.

3. Set the Dolby NR switch to be OFF.

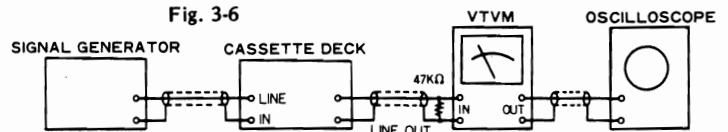

STEP	SUBJECT	INPUT SIGNAL	MEASURE OUTPUT	SETTING	ADJUSTMENT	REMARKS
1.	REC Level Adj.	Feed 1 kHz, 100mV from S.G into LINE IN.	LINE OUT VTVM Scope	Load the TEST TAPE SCT-SA. Set TAPE SELECTOR to HIGH (CrO ₂) position. 1. Depress PAUSE, PLAY and REC button. 2. Adjust the Rec Level Volume for obtaining 400 mV on VTVM. 3. Push off the PAUSE button, then record the 1 kHz signal. 4. Play back the 1 kHz signal. 5. Confirm that the output levels on both channels are 400 mV ± 2 dB on VTVM.	1. If not, turn jVR1 (REC, L-CH) and jVR1 (REC, R-CH) until output level 400 mV ± 2 dB on both channel are obtained. 2. Repeat this REC Level adj. until the indication on VTVM will be 400 mV ± 2 dB.	jVR1 (REC, L-CH), and jVR1 (REC, R-CH) are shown in Top View on page 10.
2.	Frequency Response Adj.	Feed 1 kHz 7 mV (-20 dB) and 10 kHz 7 mV (-20 dB) from S.G. into LINE IN.	Same as above	Load the TEST TAPE SCT-SA. Set TAPE SELECTOR to HIGH (CrO ₂) position. 1. Record the 1 kHz and 10 kHz signals from S.G. 2. Play back the 1 kHz and 10 kHz signals, then confirm that both output levels equal.	1. If not, adjust kVR1L for L-CH and kVR1R for R-CH slightly until the output levels will be equal.	As kVR1L and kVR1R are previously adjusted turn them slightly, if necessary.

3-4. Peak Level Indicator Adjustment

Note: 1. Set the TAPE SELECTOR to be NORMAL (LH) position.

2. Set the Dolby NR Switch to be OFF.

3. Connections are shown in Fig. 3-7.

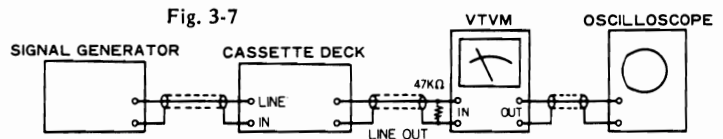

STEP	SUBJECT	INPUT SIGNAL	MEASURE OUTPUT	SETTING	ADJUSTMENT	REMARKS
1.	Peak Level Indicator Adjustment	Feed 1 kHz, 120 mV from S.G. into LINE IN	LINE OUT VTVM Scope	Load the TEST TAPE SCT-SA 1. Depress PAUSE, PLAY & REC button. 2. Adjust the REC Level Volume for obtaining 0 dB point on Level Indicator. 3. Then confirm the output levels on both channels are 500 mV ± 2 dB on VTVM.	1. If more than it, take off rR5 (68kΩ). 2. If less than it, take off rR6 (33kΩ).	After this adjustment, perform the SETTING 1 ~ 3 again.

◆ List of Sansui Test Tape

Name of TEST TAPE	Recorded Frequency	Description
SCT-F40	40 Hz	Playback Frequency Response Check
SCT-F1K	1kHz	High Frequency Equalization Check
SCT-F10k	10 kHz	REC/PB Head Adjustment
SCT-L400N	400 Hz	Playback Level and Indicator Level Adjustment
SCT-S3K	3 kHz	Speed Check and Wow & Flutter Check
SCT-LH NORMAL (LH)		Recording Bias Adjustment
SCT-SA HIGH (CrO ₂)		REC/PB Level Adjustment
SCT-CS Fe-Cr		Frequency Response Check

◆ TAPE SELECTOR Position

NORMAL Position		HIGH Position	
FUJI	FL, FXI	FUJI	FX II
MAXELL	UL, UD, XLI	MAXELL	XL II
TDK	D, AD, OD	TDK	SA
SCOTCH	TARTAN	SCOTCH	MASTER 70
	CRYSTAL MASTER 120	SONY	JHF
SONY	AHF, BHF, CHF	AGFA	STEREO CHROM
	Low-Noise	BASF	SCR
METAL Position			
AGFA	SUPER	MAXELL	MX
	SUPER COLOR	TDK	MA-R, MA
BASF	SUPER FERRO DYNAMIC	SCOTCH	Metafine
	LN Super LH I	SONY	METALLIC

4. PARTS LOCATION & PARTS LIST

Note: The printed circuit boards G-1320 and G-1328 are not provided separately. Therefore, both circuit boards are supplied together even when you order one of these.

4-1. G-1320 Main Circuit Board (Stock No. 00649701 = G-1320 & G-1328)

Component Side

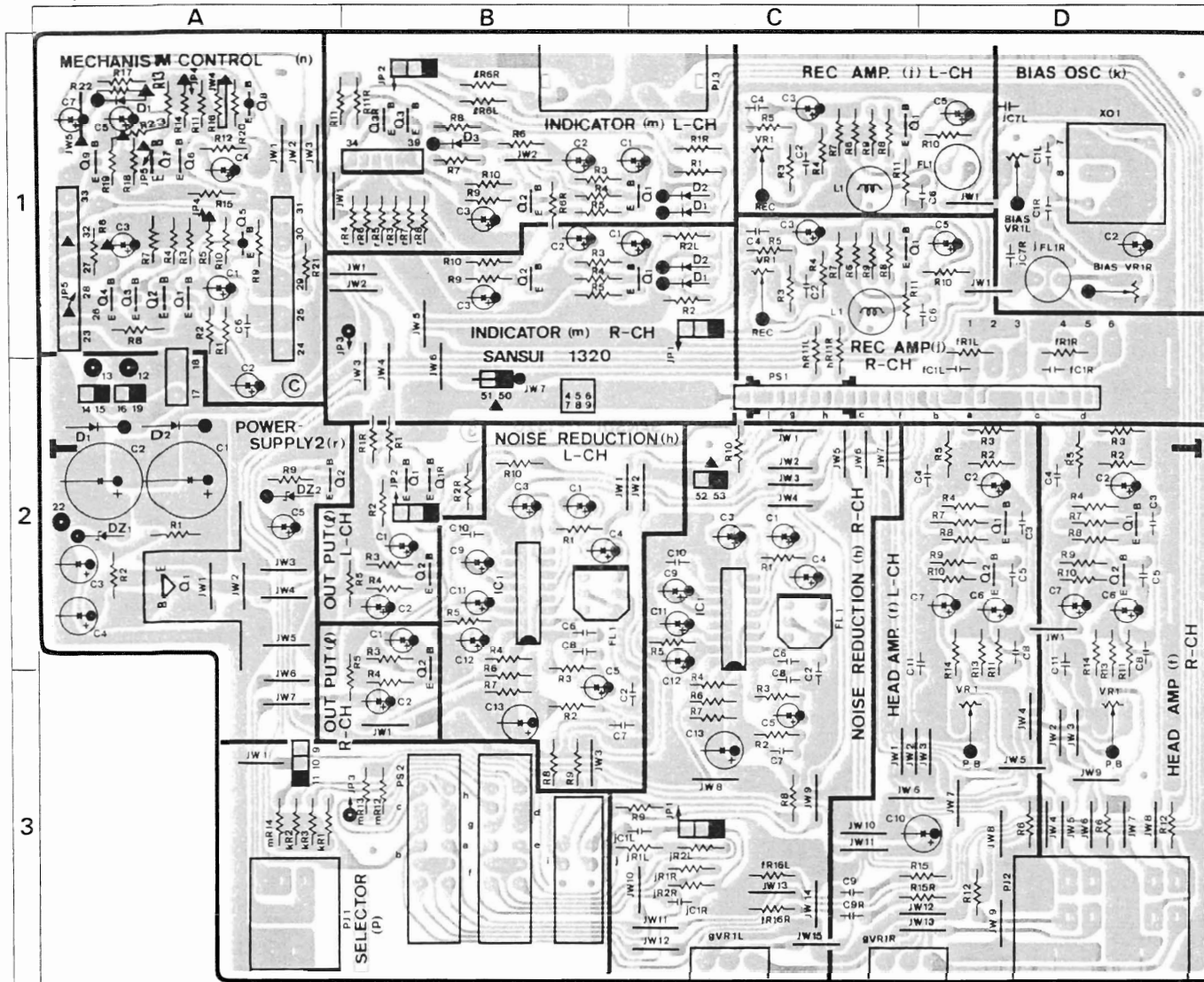

Parts List

Parts No.	Stock No.	Description	Parts No.	Stock No.	Description	Parts No.	Stock No.	Description
• Transistor								
fQ1	07225401	2SC2320L	mQ2	03068301	2SC2320	nQ8	03012701	2SA999
	03060701	2SC1313		07194801	2SC1815		07194701	2SA1015
fQ2	07225401	2SC2320L		46057201	LC945		07299601	2SA1115
	03060701	2SC1313		07299701	2SC2603	nQ9	03068301	2SC2320
jQ1	03068301	2SC2320	mQ3	03068301	2SC2320		07194801	2SC1815
	07194801	2SC1815		07194801	2SC1815		07299701	2SC2603
	07299701	2SC2603		46057201	LC945		46057201	LC945
lQ1	03068301	2SC2320		07299701	2SC2603	nQ2	03068301	2SC2320
	07194801	2SC1815		07194801	2SC1815		07194801	2SC1815
	07299701	2SC2603		46057201	LC945		46057201	LC945
lQ2	03068301	2SC2320		07299701	2SC2603	nQ3	03068301	2SC2320
	07194801	2SC1815		07194801	2SC1815		07194801	2SC1815
	46057201	LC945		46057201	LC945		07299701	2SC2603
	07299701	2SC2603		07299701	2SC2603	• IC		
mQ1	03059502	2SC945	nQ4	03068301	2SC2320	hIC1	03613600	NE646B
	07194801	2SC1815		07194801	2SC1815	• Diode		
	03068302	2SC2320		07299701	2SC2603	mD1	03111600	1S2473D
	46057201	LC945		46057201	LC945		03111800	1S1588
	07299702	2SC2603					46052500	US1035

Since some of capacitors and resistors are omitted from parts lists in this Service Manual, refer to the Common Parts List for capacitors & resistors, which was appended previously to Sansui Manual.

Parts No.	Stock No.	Description
mD2	03111600	1S2473D
	03111800	1S1588
	46052500	US1035
mD3	03111600	1S2473D
	03111800	1S1588
	46052500	US1035
rD1	03117700	10E-2
rD2	03117700	10E-2
• Zener Diode		
rDZ1	03163300	RD15E-B
	03159900	EQA01-15R
rDZ2	03162700	RD11E-B
fc4	07213400	15000p C.C.
fc8	07212800	4700p C.C.
fc9	07212500	2700p C.C.
fc11	07212400	2200p C.C.
hc2	07211300	1000p C.C.
hc6	07212800	4700p C.C.
hc7	07212900	5600p C.C.
hc8	07213700	27000p C.C.
hc10	07214000	47000p C.C.
hFL1	07196900	Filter VSL-252GS, low pass filter
jc1	07213200	10000p C.C.
jc6	07213800	33000p C.C.
fVR1	07241500	Semi Variable Resistor 50kΩ (B) PB LEVEL Adj.
gVR1	07234801	Variable Resistor 50kΩ (A) REC LEVEL
jl1	46090700	Inductor 3.9mH
jVR1	10351300	Semi Variable Resistor 10kΩ (B) REC LEVEL Adj.
kXO1	46123700	OSC Block
kVR1	10351900	Semi Variable Resistor 100kΩ (B) BIAS Adj.
jFL1	42904400	Trap Coil
mLD3	07235700	LED Indicator Ass'y, level meter
mPL1	07244800	Lamp 12V
ps1	07245000	Slide Switch (REC/PLAY)
ps2	07237100, 1	Push Switch (TAPE SELECTOR)
pJ1	07194300	Head Phone Jack
pJ2	07200300	Mic Jack
pJ3	07249100	4P Input/Output Terminal

4-2. G-1328 AMPS & BIAS Switch Circuit Board

Component Side

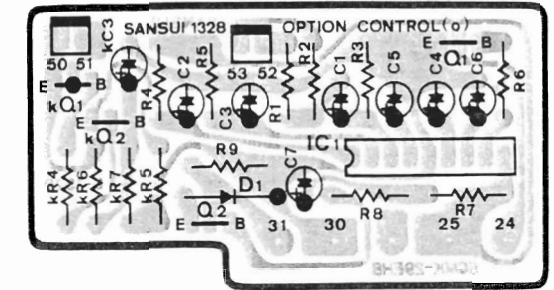

Parts List

Parts No.	Stock No.	Description
• Transistor		
kQ1	03012701	2SA999
	07194701	2SA1015
	07299601	2SA1115
kQ2	03068301	2SC2320
	07194801	2SC1815
	07299701	2SC2603
	46057201	LC945
oQ1	07206901	2SC2001
	07254901	2SC1741
	03085201	2SD438
	03069101	2SC2060
oQ2	03068301	2SC2320
	07194801	2SC1815
	07299701	2SC2603
	46057201	LC945
• IC		
oIC1	46123100	BA336
• Varistor		
oD1	03401500	MV-12

The circuit boards, G-1321 and G-1322 are not supplied as the assembled, the individual parts on the circuit boards, however are provided for orders.

4-3. G-1321 Indicator Circuit Board

Parts List

Parts No.	Stock No.	Description
	07607600	2P LED Holder
mLD1	03193700	LED (Red)
mLD2	07246200	LED (Yellow)

4-4. G-1322 Power Switch Circuit Board

Parts List

Parts No.	Stock No.	Description
	07194600	Push Switch

• Abbreviations

C.R.	Carbon Resistor	E.L.	Low Leak Electrolytic Capacitor
S.R.	Solid Resistor	E.B.	Bi-Polar Electrolytic Capacitor
Ce.R.	Cement Resistor	E.BL.	Low Leak Bi-Polar Electrolytic Capacitor
M.R.	Metal Film Resistor	Ta.C.	Tantalum Capacitor
F.R.	Fusing Resistor	F.C.	Film Capacitor
N.I.R.	Non-Inflammable Resistor	M.P.	Metallized Paper Capacitor
C.C.	Ceramic Capacitor	P.C.	Polystyrene Capacitor
C.T.	Ceramic Capacitor, Temperature Compensation	G.C.	Gimmick Capacitor
E.C.	Electrolytic Capacitor		

5. EXPLODED VIEW AND PARTS LIST

• Though every part included in mechanism ass'y is numbered in exploded view, part unlisted in the parts list are not supplied.

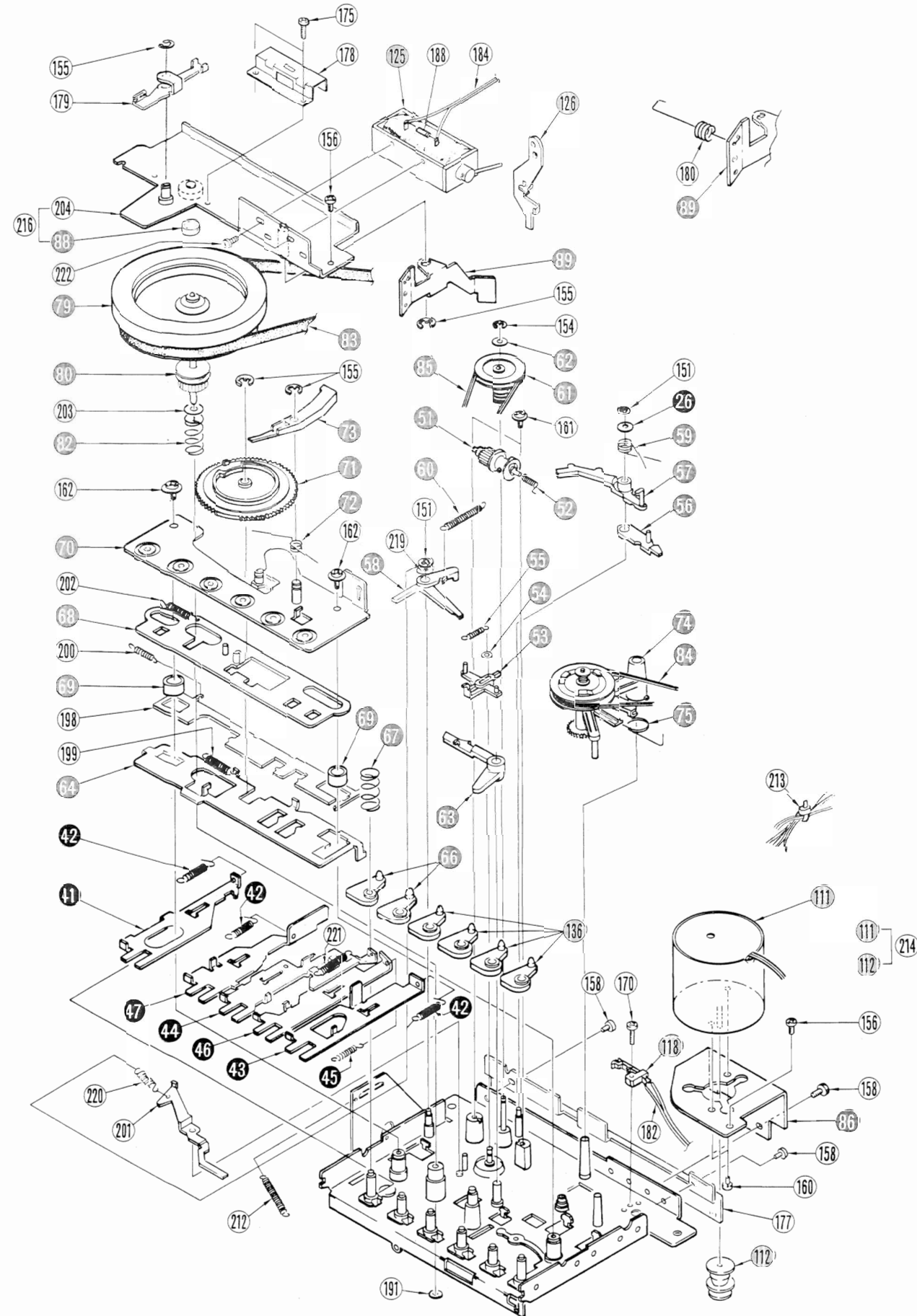

Parts List

Parts No.	Stock No.	Description
*	09416300	Sub Mechanism Ass'y
1		Chassis Ass'y
6		Cue Lever
7	09409100	Rec Inter Plate
-8		Stop Sub Plate
10	09409200	Play Idler Ass'y
11	09409300	Pause Arm
12	09409400	Idler Gear
13		Protector
14	09409500	T. Spring
17		Head Base
24	65400300	Steel Ball
25		Spring Plate
26	09417200	Washer
28	09409900	Spring
31	09417300	Washer
32	09425000	C. Spring
215	09415900	Take-up Reel Hub Ass'y, (33+36)
34	09425100	C. Spring
35	09410300	Clutch Plate
37		Lock Plate
38	09410500	Spring
41		Pause Plate
42	09410600	T. Spring
43		Rec Plate
44		Rew Plate
45		T. Spring
46		Play Plate
47		FF Plate
51	09410700	AS Cam Ass'y
52	09410800	C. Spring
53	09410900	Senser
54	09411000	Washer
55	09411100	T. Spring
56	09411200	Senser Arm A
57	09411300	Senser Arm B
58	09411400	Senser Arm C
59	09411500	Spring
60	09411600	T. Spring
61	09411700	Wrom
62	09417400	Washer
63		Stop Plate
64		Lock Plate
66		Select Arm
67		C. Spring
68		Slide Plate Ass'y
69		Collar
70		Sub Plate Ass'y
136		Select Arm B
189		T. Spring
190		Release Lever
199		T. Spring
200		T. Spring
201		FR Arm
202		T. Spring
207	09415400	Spring
208	09410100	Supply Reel Hub
18	09424800	Head Stand
20	09409600	Spring
21	09409700	C. Spring
22	09409800	Pinch Spring
29	09410000	Pinch Roller Arm Ass'y
71	09411800	Assist Gear
72	09411900	Spring
73	09412000	Start Lever
74	09412100	Tension Ass'y
75	09412200	Spring
79	09412300	Flywheel
80	09412400	FW Gear
82	09412500	C. Spring
83	09412600	Capstan Belt
84	09412700	Tension Belt
85	09412800	Auto Stop Belt
89	09418700	Rec Lever
96	09413100	Cassette Holder
113	09413300	R/P Head
114	07719500	Erase Head
116	09424700	Eject Plate
118	09413500	Leaf Switch (Muting)

Parts No.	Stock No.	Description
119	09413600	Leaf Switch (AMPS)
121	09413700	Leaf Switch (Pause)
122	09413800	T. Spring
123	09413900	T. Spring
124	09414000	Brake Arm
125	09414100	Plunger Solenoid
151	09417900	CS-type Washer
152	09418000	CS-type Washer
154	00489000	E-type Washer
155	00489200	E-type Washer
156	07710600	DT. Screw
157	09416400	DT. Screw
158	07687500	DT. Screw
160	09418600	Sems Screw (Motor)
161	09416500	Tapping Screw
162	09416600	Tapping Screw
163	09416700	N. Screw (Head)
166	09416800	DT. Screw
168	09416900	N. Screw
169	09417500	Washer
170	09417000	DT. Screw
172	09417100	Sems Screw
174	09414200	Mechanism Cover Ass'y
175	00455300	Tapping Screw
176	09414300	Cylinder Ass'y
180	09414400	Rec Spring
191	09417600	Washer
194	09417700	Washer
196	09414600	Counter
197	09414700	Counter Belt
203	09452600	Washer
205	09415200	Cassette Case Ass'y
206	09415300	Eject Ass'y
210	09415500	Button Holder Ass'y
212	09424900	T. Spring
214	09415600	Motor Ass'y, (111+112)
216	09452700	Capstan Holder Plate Ass'y, (88+204)

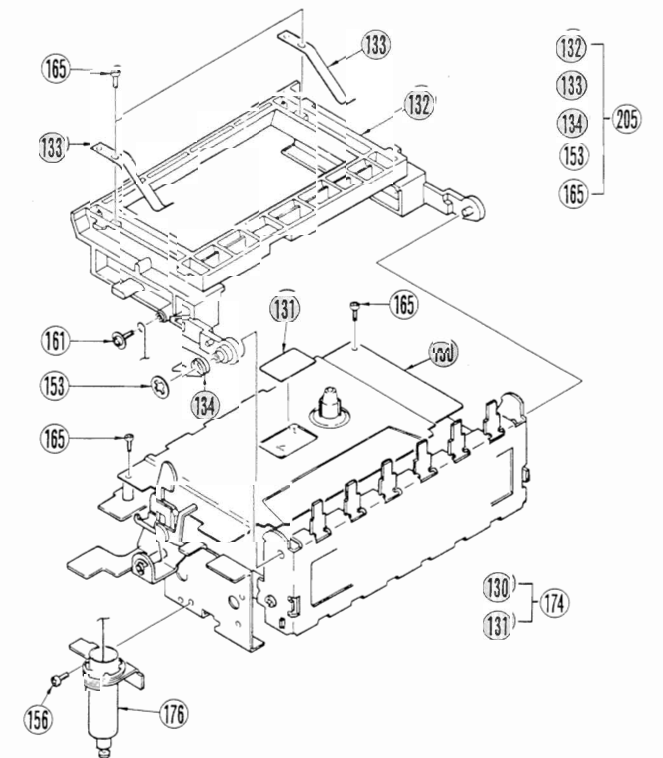

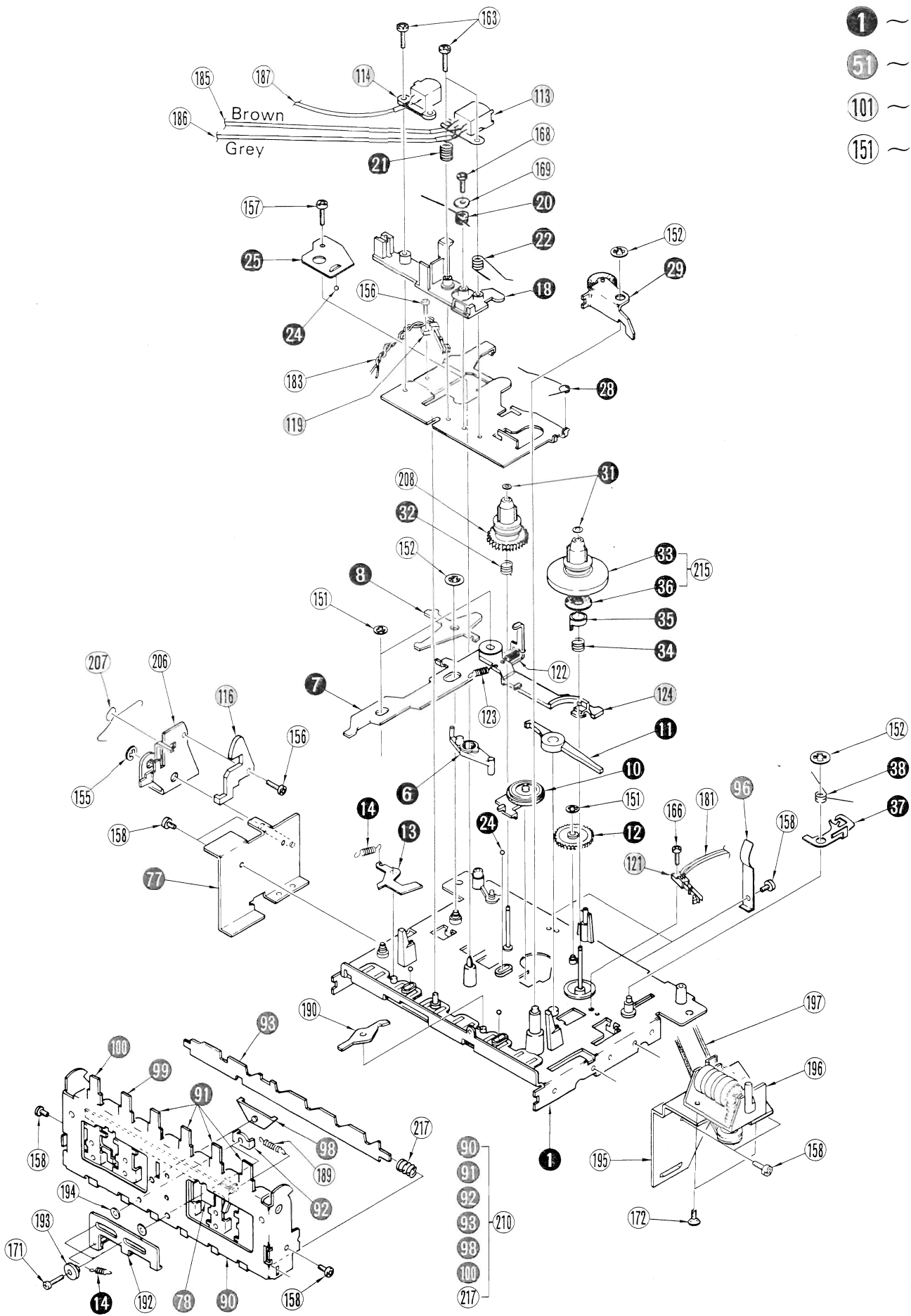

1 ~ 50

51 ~ 100

101 ~ 150

151 ~ 216

6. MAIN PARTS REPLACEMENT (See 5. Exploded View)

A. Replacement of mechanism chassis

- 1) Remove bonnet, bottom plate, lid ass'y and front panel.
- 2) Cut the wire from mechanism and their nylon bands.
- 3) Pull out flexible wire.
- 4) Loosen four screws fixing mechanism chassis.

B. Replacement of motor ass'y 111 + 112

- 1) Remove bonnet, bottom plate, lid ass'y and front panel.
- 2) Cut the wire from motor 111.
- 3) Loosen One screw fixing input/output terminal.
- 4) Remove left and right side panel slowly.
- 5) Loosen two screws 155 158 fixing motor mounting plate 89.
- 6) Loosen two screws 160 fixing motor ass'y.

C. Replacement of capstan belt 83, tension belt 84 and auto stop belt 85

- 1) Remove mechanism chassis from set.
 - 2) Loosen two screws 222 fixing plunger solenoid 125.
 - 3) Loosen one screw 156 fixing plunger mounting plate 87.
 - 4) Take out plunger mounting plate 87.
 - 5) Take out tension belt 84.
 - 6) Take out capstan belt 83.
 - 7) Pull out capstan flywheel 24.
- Note: Pay attention not to loose spring 32 and washer 191.
- 8) Take out auto stop belt 85.

D. Replacement of counter belt 197

- 1) Remove bonnet, lid ass'y and mechanism panel 180.

E. Replacement of Take-up reel hud ass'y 33 + 36 and supply reel hub 200

- 1) Remove lid ass'y and mechanism panel 180.
- 2) Take out ply-washer 31.

F. Replacement of play idler.

- 1) Remove lid ass'y and mechanism panel 180.
- 2) Pull out plastic-tack at play idler ass'y 10. (See Fig. 6-1).

Fig. 6-1

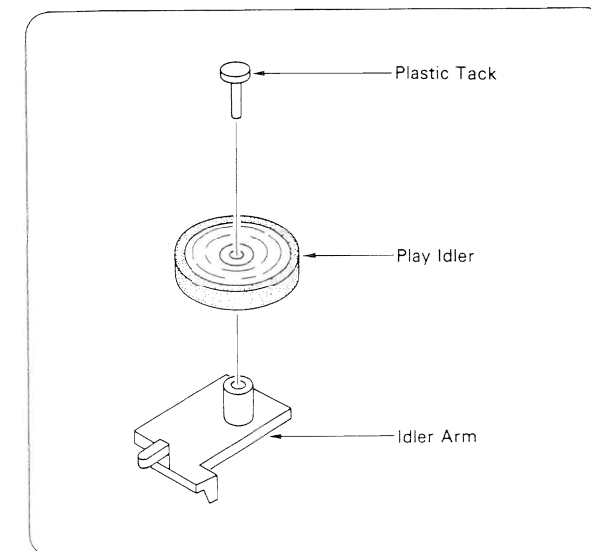
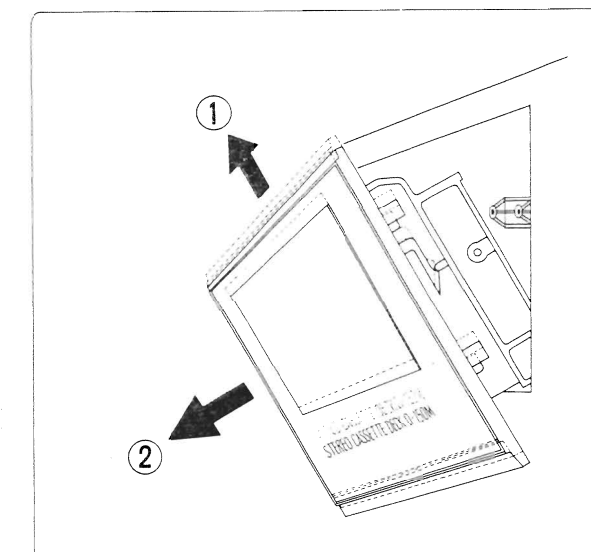

Fig. 6-2



Abbreviations

1. Pan Head Tapping Screw . . . PT Type	5. Pan Head SEMS B Screw . . . PSB Type	9. Flat Counter Sunk Wood Screw . . . FC Type	13. Binding Head SEMS B Screw . . . BSB Type	17. Toothed Lock Washer (External) . . . TLE Washer
2. Washer Head Tapping Screw . . . WT Type	6. Binding Head SEMS F Screw . . . BSF Type	10. Round Head Wood Screw . . . RH Type	14. Spring Washer . . . S Type	18. Wave Washer
3. Pan Head Screw . . . P Type	7. Binding Head Screw . . . B Type	11. Hex. Socket Setscrew . . . SC Type	15. Plain Washer . . . P Type	19. Hexagon Nut H Type Nut
4. Pan Head SEMS A Screw . . . PSA Type	8. Flat Counter Sunk Head Screw . . . F Type	12. Slot Type Setscrew . . . SS Type	16. Retaining Ring (E Washer) . . . E Type	

7. SCHEMATIC DIAGRAM

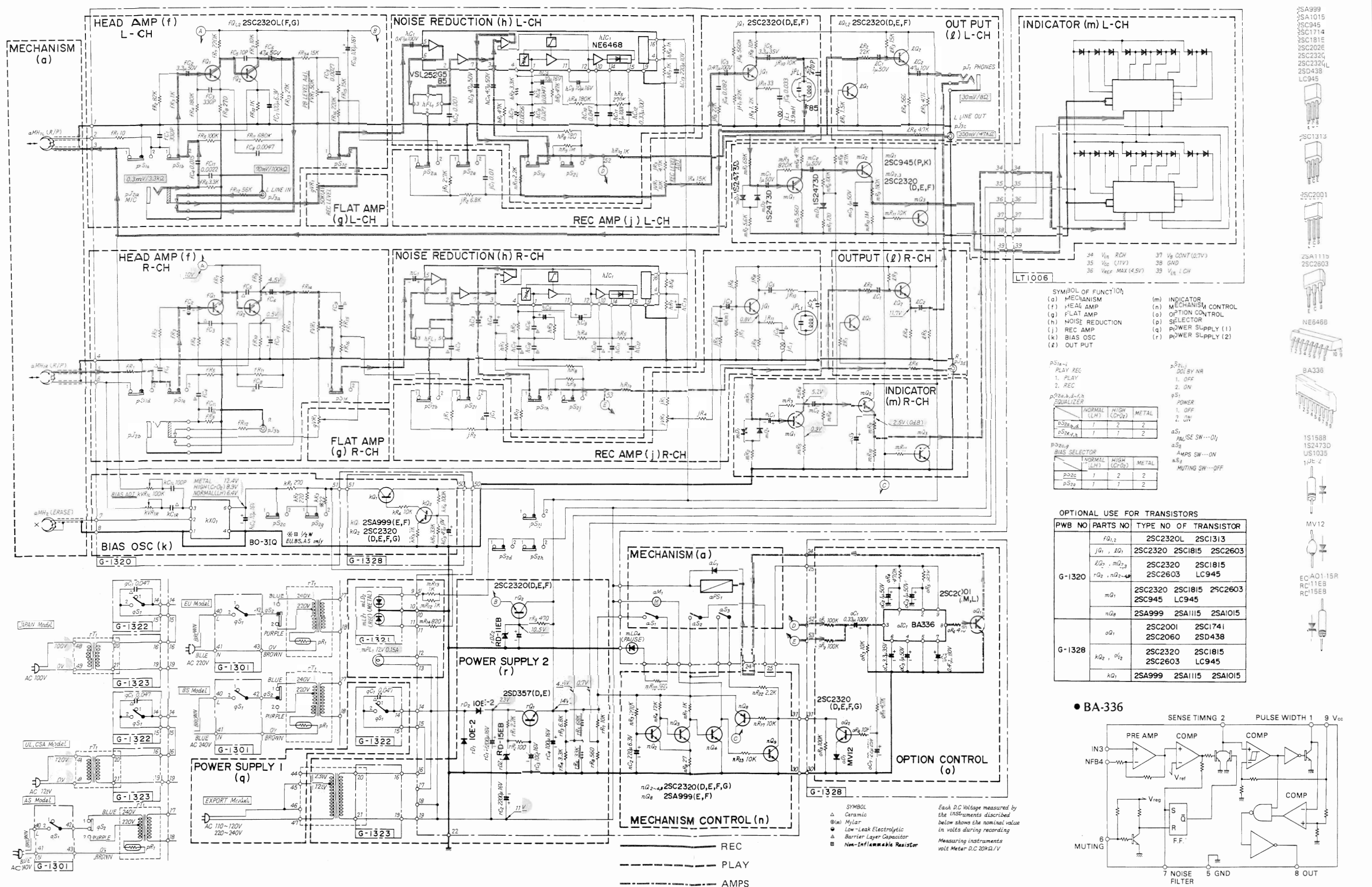

SYMBOL OF FUNCTION

(a) MECHANISM	(m) INDICATOR
(f) HEAD AMP	(n) MECHANISM CONTROL
(g) FLAT AMP	(o) OPTION CONTROL
(h) NOISE REDUCTION	(p) SELECTOR
(j) REC AMP	(q) POWER SUPPLY (1)
(k) BIAS OSC	(r) POWER SUPPLY (2)
(l) OUT PUT	

PS1a-1
1. PLAY REC
2. REC

PS2a, b, d-f
EQUALIZER

	NORMAL (LH)	HIGH (CH)	METAL
PS2a, d	1	2	2
PS2b, f	1	1	2

PS2c, g
BIAS SELECTOR

	NORMAL (LH)	HIGH (CH)	METAL
PS2c	1	2	2
PS2g	1	1	2

PS2j
20L BY NR
1. OFF
2. ON

PS3
POWER
1. OFF
2. ON

AS1
PAUSE SW---01

AS2
AMPS SW---ON

AS3
MUTING SW---OFF

OPTIONAL USE FOR TRANSISTORS

PWB NO	PARTS NO	TYPE	NO OF TRANSISTOR
G-1320	fQ _{1,2}	2SC2320L	2SC1313
	JQ ₁ , KQ ₁	2SC2320	2SC1815 2SC2603
	LQ ₁ , MQ _{1,2}	2SC2320	2SC1815
G-1328	rQ ₂ , nQ ₂₋₄	2SC2603	LC945
	mQ ₁	2SC2320	2SC1815 2SC2603
	nQ ₃	2SC945	LC945
G-1322	aQ ₁	2SA999	2SA1115 2SA1015
	bQ ₁	2SC2001	2SC1741
	kQ ₂ , oQ ₂	2SC2060	2SD438
G-1323	kQ ₁ , oQ ₁	2SC2320	2SC1815
	lQ ₂	2SC2603	LC945
	kQ ₃	2SA999	2SA1115 2SA1015

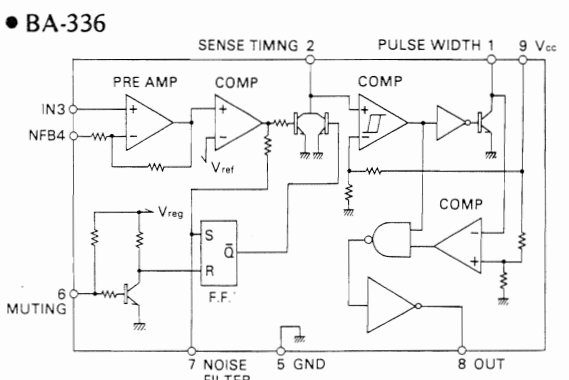

Each D.C. Voltage measured by the instruments described below shows the nominal value in volts during recording. Measuring instruments volt Meter D.C. 20K1/V

- 2SA999
- 2SA1015
- 2SC945
- 2SC1174
- 2SC1815
- 2SC2026
- 2SC2320
- 2SC2320L
- 2SD438
- LC945
- 2SC1313
- 2SC2001
- 2SA1115
- 2SC2603
- NE6468
- BA336
- 1S1588
- 1S2473D
- US1035
- 10E-2
- MV12
- EA01-15R
- RC11EB
- RC15EB

1
2
3
4
5

8. OTHER PARTS

8-1. Front View

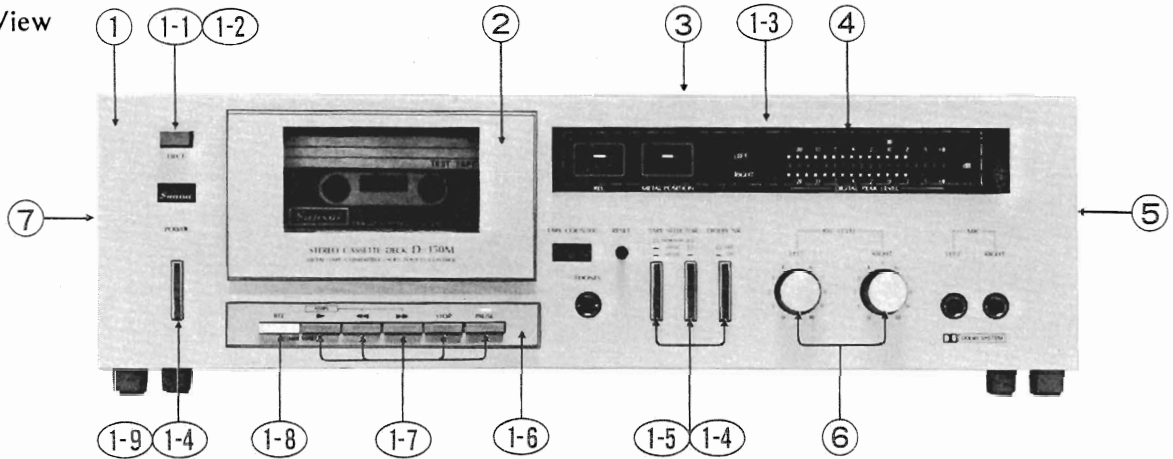

8-2. Top View

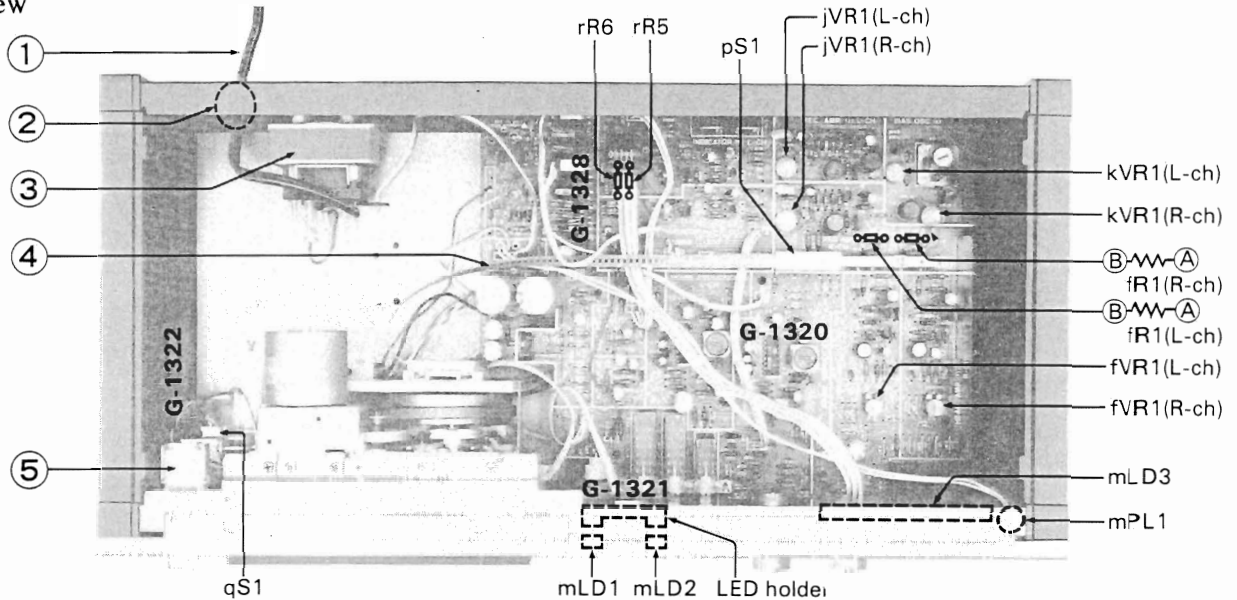

Parts List <Front View>

Parts No.	Stock No.	Description
3	07601400	Bonnet
4	07629310	Meter Frame Ass'y
5	07602010	Side Panel (R)
7	07601910	Side Panel (L)
<Silver Model>		
1	09404300	Front Panel Ass'y
1-1	53194910	Knob, eject
1-2	53967820	Knob Guide, eject
1-3	09407300	Meter Cover
1-4	07580300	Knob, power, tape selector, dolby
1-5	07581300	Knob Guide, tape selector, dolby
1-6	09444800	Control Button Panel Ass'y
1-7	09403700	Control Button, play, rew, ff, stop, pause
1-8	09403900	Control Button, rec
1-9	07628000	Knob Guide, power
2	09404600	Lid Ass'y
6	07614200	Knob, rec level
<Black Model>		
1	09404400	Front Panel Ass'y
1-1	53194810	Knob, eject
1-2	53967720	Knob Guide, eject
1-3	09407500	Meter Cover

Parts No.	Stock No.	Description
1-4	07580500	Knob, power, tape selector, dolby
1-5	07581200	Knob Guide, tape selector, dolby
1-6	09444900	Control Button Panel Ass'y
1-7	09403800	Control Button, play, rew, ff, stop, pause
1-8	09403900	Control Button, rec
1-9	07595700	Knob Guide, power
2	09404700	Lid Ass'y
6	07614500	Knob, rec level

Parts List <Top View>

Parts No.	Stock No.	Description
1	38005400	Power Supply Cord
2	39106000	Strain Relief
3	15000901	Power Transformer
4	60560600	Flexible Wire Ass'y
5	09403500	Eject Bar

9. PACKING LIST

Parts No.	Stock No.	Description
1	91263810	Polyethylene Bag
2	07641000	Styrofoam Packing
3	09403100	Carton Case (Silver Model)
	09403300	Carton Case (Black Model)

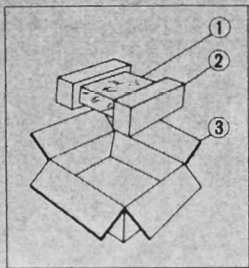

10. ACCESSORY LIST

Stock No.	Description
38103300	Pin Plug Cord
46123400	Operating Instruction



SANSUI ELECTRIC COMPANY LTD.: 14-1, Izumi 2-chome, Suginami-ku, Tokyo 168 Japan PHONE:(03) 323-1111/TELEX:232076
 SANSUI ELECTRONICS CORPORATION: 1250 Valley Brook Ave. Lyndhurst, N.J. 07071 U.S.A.
 333 West Alondra Blvd. Gardena, California 90247 U.S.A.
 3036 Koapaka St. Honolulu, Hawaii 96819 U.S.A.
 SANSUI ELECTRONICS (U.K.) LTD.: Unit 10A, Lyon Industrial Estate, Rockware Avenue, Greenford, Middx UB6, OAA, England
 SANSUI ELECTRONICS G.M.B.H.: Arabella center, 6 Frankfurt AM Main, Lyoner Strasse 44-48, West Germany